

REV.	ECN. NO.	DESCRIPTION	ENG	DATE
X1		ISSUED	MIKE	06/12/14'
X2		MODIFY ESATAP EXTERIOR	MIKE	06/17/14'
X3		ADD W/O SCREW TAB OPTION	MIKE	10/09/14'

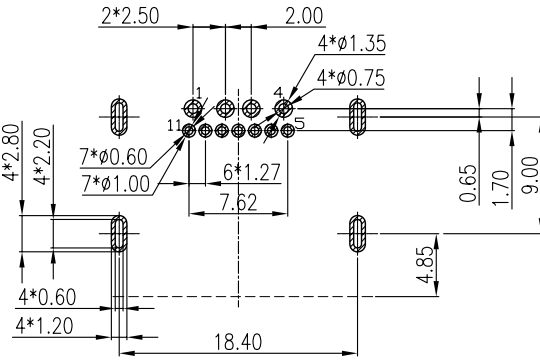

RECOMMEND P.C.OARD LAYO T=1.20mm
 PCB TOLERANCE:±0.05

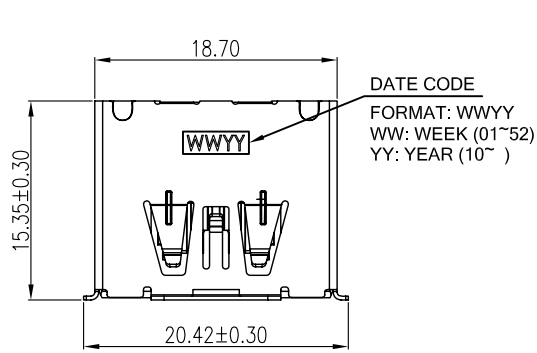
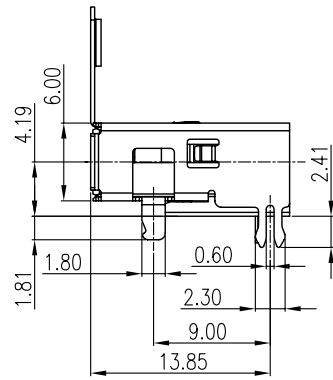
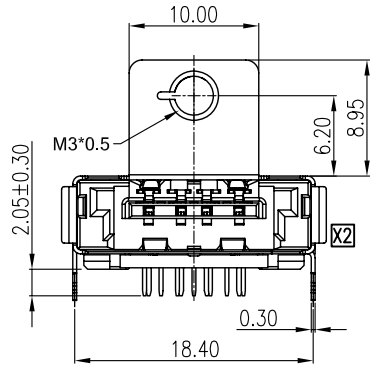

PART. NUMBER

ESAR-1X 11 - B K * 3 I 01

- ①
- ②
- ③④⑤⑥⑦

- ① CONNECTOR:
 ESAR-1K: ESATAP DIP TYPE CONNECTOR WITH SCREW TAB
 ESAR-1L: ESATAP DIP TYPE CONNECTOR W/O SCREW TAB
- ② POSITION:
 11: 11 POSITIONS
- ③ INSULATOR MATERIAL:
 B: LCP
- ④ INSULATOR COLOR:
 K: BLACK
- ⑤ CONTACT PLATING:
 1: GOLD FLASH
 8: GOLD 6u"
- ⑥ SHIELD PLATING
 3: NICKEL PLATING
- ⑦ PACKING
 T: TRAY

PIN DEFINITON

USB		ESATA	
NAME	TYPE	NAME	TYPE
P1	VBUS	P5	GND
P2	D-	P6	A+
P3	D+	P7	A-
P4	GND	P8	GND
		P9	B-
		P10	B+
		P11	GND

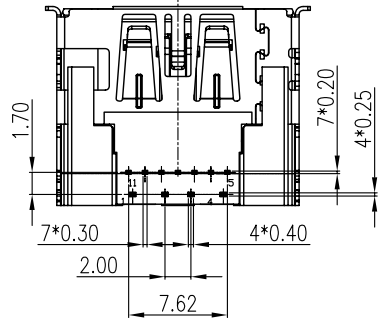
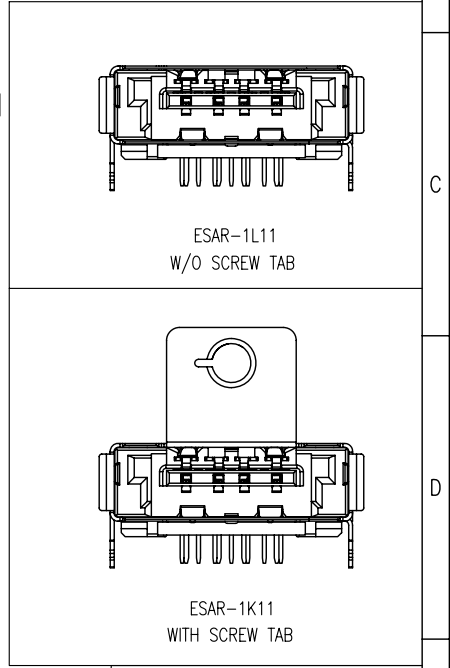

- NOTES:
 1. MATERIALS
 USB Terminal: Phosphor Bronze
 Gold on contact area,
 80u" matte Tin on solder tail,
 both over 30u"Nickel under-plating.
 E-SATA Terminal: Brass
 Gold on contact area,
 80u" matte Tin on solder tail,
 both over 30u"Nickel under-plating.
 Housing: LCP+30% G.F.,UL94V-0
 Cover: LCP+30% G.F.,UL94V-0.
 Shell: Stainless steel,
 50u" Nickel plating overall.
2. RoHS compliant

PRELIMINARY
 NOT RELEASED



GENERAL TOLERANCE X.±0.50 .X±0.38 .XX±0.25 .XXX±0.15	ANGLE TOLERANCE X°±2° .X°±1° .XX°± .XXX°±	DRAWN MIKE	DATE 06/17/14'	TITLE. eSATAp DIP TYPE CONNECTOR
MATL SEE BOM	FINISH SEE NOTES	CHECKED	DATE	
SCALE N/A	UNIT mm	APPROVED	DATE	DRAWING NO. GT23-250180
SHEET 1 of 1				SIZE A4 REV. X3